

ESSENTIALS

ELECTRIC VEHICLES Security Solution

Selected by
automotive experts
and trainers in
mechanics to make
your life easier



TOOLWEB SM  an **ISN**
company

TOOLWEB.CA

info@isncanada.ca | 1-888-327-0222

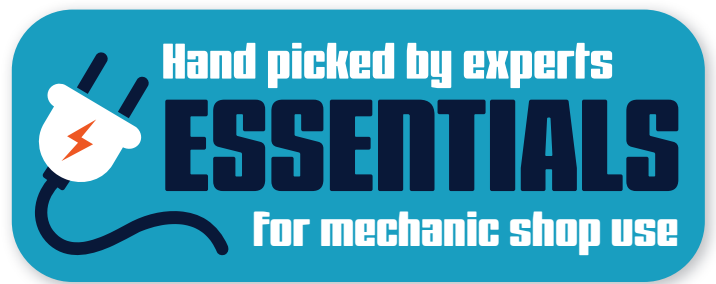

CTUKIT-24

BI-MATERIAL INSULATED TOOL KIT - UNDERVOLTAGE WORK 1,000 V AC - 1,500 V DC

Kit includes: Flat head screwdriver 4 x 125 mm, Flat head screwdriver 6 x 150 mm, Flat head screwdriver 8 x 175 mm, Screwdriver PZ 1, Screwdriver PZ 2, Insulated wire stripper 160 mm, Insulated bent nose pliers 160 mm, Insulated cable cutter 160 mm



CTUMORCEV2

WORKSHOP TROLLEY FOR WORK ON ELECTRIC AND HYBRID VEHICLES

- Storage of all necessary equipment: PPE, locking and signalling equipment and insulated tools in one place.
- Torsion-resistant, profiled construction in heavy-gauge steel.
- Corrosion- and scratch-resistant (matte powder coating).
- Integrated locker for bulky parts.
- 2 fixed and 2 swivel wheels (one with brake) - Ø100 mm wheels.
- Load capacity per drawer: 25 kg (50 kg for the lowest drawer 210 mm high).

INSULATED SCREWDRIVERS



1,000V INSULATED SCREWDRIVERS

- Milwaukee 1000V insulated screwdrivers are OSHA approved and provide an uncompromising safety rating
- Tested and certified to insulated tool standards: IEC 60900:2012, ASTM F1505-10, NFPA 70E, VDE & GS
- Flame retardant & impact resistant handle and shank



MLW48-22-2204 4PC SET

P#2 (4"), SL 1/4" (6"), SL 3/8" (8"), P#1 (3")



WIH91890

26 PIECE HYBRID & EV ESSENTIALS TOOL KIT

- Set Includes: Sockets, Ratchets, Extension Bars, Wrenches, Pliers, Cutters, Screwdrivers, Cable Stripping Knife, and Tweezers
- Custom-fit trays with finger-recesses for easy retrieval
- Exact fit precision machined tips for reduced cam-out
- Rigorous heat-treatment process for maximum strength
- Slip guard handle designed for added protection
- 18.1" L x 14.56" W x 4.33" H Tool Case



MLW48-22-2202 3 PIECE 1000V SET

- (1) #1 ECX - 4" (48-22-2241)
- (1) #2 Phillips - 4" (48-22-2212)
- (1) 1/4" Slotted - 6" (48-22-2221)



MLW48-22-2212 #2 PHILLIPS - 4 IN. 1000V



MLW48-22-2222 5/16 IN. SLOTTED 7 IN.



WIH3691 7 PIECE HEX L-KEY SET

- Insulated L Key Individually tested to 10,000 volts AC and rated to 1,000 volts AC for safety and peace of mind
- Professional Series Long Life Insulated
- Double Insulated Red Over Yellow
- Insulated Hex Metric L-Key Set, 7 Piece. Set includes: 3.0, 4.0, 5.0, 6.0, 8.0, 10.0, 12.0mm. Blade Chrome-vanadium steel, hardened. 1000 Volt Rated.



WIH33478 5 PIECE T-HANDLE HEX SCREWDRIVER SET - METRIC

- Set Includes: 4.0, 5.0, 6.0, 8.0 10.0mm
- Individually tested to 10,000 volts AC and rated to 1,000 volts AC for safety and peace of mind
- Parallel flats for roll-off prevention
- Tip profile labeled on cap for easy identification
- Wiha premium quality tool steel for strength and durability
- Black oxide finish for corrosion protection
- Exact fit precision machined tip for reduced cam out



WIH32876

66 PIECE PLIERS, CUTTERS AND SCREWDRIVER SET

Set Includes: T- Handle 4.0, 5.0, 6.0mm | T-Handle 3/16, 7/32, 5/32, 5/16, 1/4, 3/8" | Nut Driver 11/32, 1/4, 3/8, 5/16, 7/16" | Long Nose Pliers 9.0" | Long Flat Nose Pliers 6.3" | BiCut Compound Cutter 8.0" | Stripping Pliers 6.3" | Industrial Cable Cutters 8.0" | Adjustable Wrench 8.0" | Lineman's Pliers With Crimpers 9.0" | Slotted 2.0x60mm, 2.5x75mm, 3.0x100mm, 4.0x100mm, 4.5x100mm, 5.5x125mm, 6.0x150mm, 8.0x175mm, 10.0x200mm | Phillips #2x100mm, #0x60mm, #1x80mm, #3x150mm | Square #2x150, #1x100mm | Xeno #2x100mm, #1x80mm | Torx T8, T10, T15, T20, T25, T30 | 3/8" Drive Ratchet | Cable Stripping Knife 50mm | Hex Key 10.0x220mm | 3/8" Drive Extension Bar | Cordura Canvas Tool Bag 23"



WIH32081

5 PIECE SOFTFINISH CUSHION GRIP SCREWDRIVER TRAY SET

- Set Includes: Slotted 4.5, 5.5, 6.5mm and Phillips #1, #2
- Dual durometer construction for long-lasting durability
- Parallel flats for roll-off prevention
- Black oxide finish for corrosion protection



TIT17237

7 PIECE ELECTRICAL SCREWDRIVER

Sizes included: 3" x #0, 4" x #1 and 4" x #2 Phillips and 3" x 1/8", 4" x 5/32", 5" x 7/32" and 6" x 1/4" Slotted.



VES2005PBU

BALL GRIP 5PC. SET

Includes No.200 -5(3/16)x3", -6(1/4)x4", +1x3", +2x4", +3x6", VDE certified, reliable 100% dielectric inspection conducted, Ergonomic BALL GRIP for anti-fatigue and various way of driving, Non-step slim covered blade shank for preventing electrical short circuit, High precision black point tip, High wear-resistance and durable fully hardened blade by optimum heat treatment, Magnetized Tip



CRSCTVDESDS

7 PIECE VDE SET

- Size : Phillips® #0 #1 #2 Slotted 1/8 in 5/32 in 3/16 in 1/4 in
- This 7-piece set includes four slotted drivers and three Phillip's for a complete offering
- Insulated handles rated to 1,000 volts but tested up to 10,000, for peace of mind while working in electrical spaces
- Thin wall insulation jacket for greater access
- High strength heat-treated alloy tips



MEGADORA INSULATED SCREWDRIVERS

- Insulated Screwdrivers Series certified by VDE (IEC60900), International certification authority
- Safe and secured double insulation layer
- Highly precise tip-end (black oxide finish)
- Chrome-vanadium steel, fully hardened
- Flat Surface Grip



VES960P3150
NO.960
PH3X150

#3 Phillips Screwdriver 10.91" (277.0mm), Magnetic



VES960S6100
NO.960
S6X100

Slotted Screwdriver 8.35" (212.0mm), Magnetic



VES960PS3150
NO.960PS
PS3X150

P53 Phillips Screwdriver 8.35" (212.0mm), Magnetic

INSULATED CUTTERS • PLIERS

CRESCENT

VDE INSULATED PLIERS

- Crescent's VDE Pliers are rated up to 1000 volts, but tested up to 10,000. Backed by VDE certification, these pliers are truly professional grade.
- Insulated design for use in high-voltage areas with up to 1000V of alternating current, VDE certified, and built to meet IEC/EN 60900-2012
- Laser hardened cutting edges cut clean
- Ergonomic anti-slip handles maximize comfort and grip strength



LONG NOSE

CRS6LVDE - 6" • CRS8LVDE - 8"



LINEMAN'S

CRS6LMVDE - 6" • CRS7LMVDE - 7"
CRS8LMVDE - 8"

INSULATED TWEEZERS

- Slip Guards at Tips For User Safety
- Two Layer High Contrast Insulated Coatings
- Tweezers are Carbon Steel With Chrome Nickel Plate
- Meets: ASTM, EN/IEC, OSHA, NFPA, CSA Insulation Standards



WIH32981

3 PIECE INSULATED INDUSTRIAL PLIERS-CUTTERS SET

- Set Includes: Insulated Industrial Combination Pliers 8.0", Insulated Industrial Diagonal Cutters 8", Insulated Industrial Long Nose Pliers 8"
- Individually tested to 10,000 volts AC and rated to 1,000 volts AC for safety and peace of mind
- Dual durometer construction for long-lasting durability
- Slip guard handle design for added protection
- Standard industrial brushed finish for surface endurance
- Induction hardened cutting edges and jaws for superior sharpness and longevity



HIGH LEVERAGE INSULATED PLIERS

- 1,000 Volt Rated
- Securely Grips work
- Over molded handles for comfort
- Vise Grip lifetime warranty
- The handles allow for comfort and are slip resistant.



VGP10505869NA
VISE-GRIP 8 IN. LONG NOSE



VGP10505873NA - 7" • VGP10505874NA - 8"
VISE-GRIP 7 IN. COMBINATION



WIH75220
STRAIGHT BLUNT 8"



WIH75304
SERRATED, ANGLED BLUNT 200MM (8")

INSULATED TOOLS



WIH12851
INSULATED 1/4" X 140 MM DRIVE RATCHET
 · EN ISO 6798, BS EN 26789, ASME B107



KNP983350
REVERSIBLE TORQUE WRENCH- 1,000V INSLTD-3/8IN DR'
 · Range of Application: 5 - 50 Nm
 · Reversible for tightening of left-handed threads
 · Lockable torque adjustment



KNP9831
KNIPEX 3/8 IN. DRIVE INSULATED REVERSING RATCHET
 · Insulated tool meets current ASTM and IEC standards
 · Precise ratcheting mechanism ensures smooth action



WIH30114
INSULATED RATCHETING TORQUE WRENCH 1/4" DRIVE 5-25 NM
 · Fully Visible Reading Scale For Easy Reading No Hassle Adjustment
 · Locking Endcap Torque Adjuster For Easy Adjustment
 · Accuracy +/- 10% Accuracy
 · Dual Scale Reading Ft./lbs. -



WIH30138
INSULATED RATCHETING TORQUE WRENCH 3/8" DRIVE 5-50 NM
 · Hex Power Bits With Exact Fit Machined Tips
 · Natural Blasted Finish
 · CRM-72 Modified Tool Steel-Maximum Performance Through Hardened



WIH20196
13 PIECE INSULATED OPEN END WRENCH TRAY SET - METRIC
 · Professional Series Long Life Insulated
 · High Visibility Coatings
 · Double Covered Insulation Red Over Yellow
 · Sizes: 8mm, 10mm, 11mm, 12mm, 14mm, 15mm, 16mm, 17mm, 18mm, 19mm, 22mm, 24mm



WIH28789
11 PIECE INSULATED TORQUEVARIO-S (10-50 IN/LBS) AND SLIMLINE BLADE SET
 · Set Includes: Insulated TorqueVario-S SoftFinish Handle (10-50 in/lbs.) | Slimline blade holder - 6.75" OAL Torque Adjustment Tool | Heavy-duty Canvas Velcro-lock Pouch | 8 Insulated SlimLine Blades - Slotted 4mm, 6.5mm, Phillips #1, #2, Square #1, #2, Terminal Xeno #1, #2

INSULATED DRIVE EXTENSION BAR



WIH12857
3/8" X 250 MM
 · Insulated 1000 Volt Rated 10,000 Volt Tested
 · Meets ASTM F1505, EN/IEC 60900, NFPA-70E
 · 13 Point Wrench, Precision Geared



WIH12855
1/4" X 100 MM
 · Exact fit precision machined tips
 · Made from WIHA CRM-72 modified Tool Steel
 · Through Hardened Durability



WIH12854
1/4" X 50 MM
 · Insulated 1000 Volt Rated 10,000 Volt Tested
 · Meets ASTM F1505, EN/IEC 60900, NFPA-70E
 · Additional Durable Soft Grip



WIH12856
3/8" X 125 MM
 · Handle Anti-Static ESD Safe Material
 10⁶-10⁹ ohms Resistance
 · Allows for safe controlled dissipation of static build up
 · Exact Fit Precision Machined Tips

GLOVES

ASLRIG11Y070 (size 7)
 ASLRIG11Y080 (size 8)
 ASLRIG11Y090 (size 9)
 ASLRIG11Y100 (size 10)
 ASLRIG11Y110 (size 11)
 ASLRIG11Y120 (size 12)
**ACTIVARMR® RUBBER
 INSULATED GLOVES**

Class 0, Maximum Voltage Use
 AC DC: 1,000V ac | 1,500V dc



- Applications with risk of touch voltage AC ≥ 50 V 1
- Hybrid engine manufacturing and repair
- Mass transit repair and maintenance
- Length: 11"

ASLRIG11R070 (size 7)
 ASLRIG11R080 (size 8)
 ASLRIG11R090 (size 9)
 ASLRIG11R100 (size 10)
 ASLRIG11R110 (size 11)
 ASLRIG11R120 (size 12)
**ACTIVARMR® RUBBER
 INSULATED GLOVES**

Class 0, Maximum Voltage Use
 AC DC: 1,000V ac | 1,500V dc



- Applications with risk of touch voltage AC ≥ 50 V 1
- Hybrid engine manufacturing and repair
- Mass transit repair and maintenance
- Length: 11"



**SAS6467 (M) - SAS6468 (L)
 SAS6469 (XL) - SAS6470 (XXL)**

PAIR OF PROTECTIVE OVER GLOVE

Wear over rubber electric insulating service gloves. Protects rubber insulating gloves from punctures and abrasion.



**ASLRIGCVSBAG14 (14") - ASLRIGCVSBAG16 (16")
 ACTIVARMR 96-001 RIG CANVAS GLOVE BAG**

- Increased durability: The ActivArmr 96-001 canvas storage bag is made from 100% cotton, with a heavy canvas construction that prevents your electrically insulated gloves from being damaged by folding, heat, sunlight, humidity, ozone and chemical substances



**CTUGI-01408-RRI (size 8/M)
 CTUGI-01409-RRI (size 9/L)
 CTUGI-01410-RRI (size 10/XL)
 CTUGI-01411-RRI (size 11/XXL)**

**14" (36CM) LONG,
 CLASS 0, RED
 INSULATING GLOVES
 WITH ROLLED CUFF**

MAX. OPERATING VOLTAGE
 1000VAC/1500VDC



**RIGLVCVR070 (size 7) - RIGLVCVR080 (size 8) - RIGLVCVR090 (size 9)
 RIGLVCVR100 (size 10) - RIGLVCVR110 (size 11) - RIGLVCVR120 (size 12)
 LOW VOLTAGE CLASS 0 & 00 LEATHER COVER**

- Robust goatskin leather: Abrasion, puncture and cut resistance
- ASTM D120 and EN 60903 compliance: Assured effectiveness
- ActivArmr96-002 protectors are made from premium goatskin leather, enhancing hand safety when conducting electrical work



**CTUCG361
 STORAGE CASE FOR INSULATING
 GLOVES CLASS 00, 0, 1**

- Made of repellent reinforced fabric (1200D) for the transportation of insulating gloves in vehicles and tool boxes.
- Rear loop for belt carriage and transparent pocket (for instructions/or identification).
- Velcro fastening.



**CTUCG98108 (size 8) - CTUCG98109 (size 9)
 CTUCG98110 (size 10) - CTUCG98111 (size 11)
 LEATHER OVERGLOVES
 FOR INSULATING GLOVES**

- Ensure mechanical protection for insulating gloves (class 00 & 0), CG-05 and CG-10.
- They are resistant to flame and contact heat of 100°C for 10 s according to EN 407.
- Silicone goat grain leather, Kevlar thread stitching.
- Complies with standard EN 388: 2016 2122X & EN 407: 2004 412X4X



CTUALPVLD (UP TO Ø 42 CM)
CTUALPVXLD (UP TO Ø 62 CM)
LOCKING COVER FOR HANDWHEEL

- Provides an ideal lock for steering wheel.
- Allows to display a personalized message during the lock-out procedure thanks to the transparent pocket (A5 size).
- Strap closure at the back with metal eyelets Ø 10 mm for inserting a padlock and self-gripping part.



KNP986705
RUBBER COVER 20" - 1,000V INSULATED

- For additional protection when working with or near live parts 20" Size
- Insulation standard: DIN/EN IEC 61112

CTUKITRCTST1
TST SECURITY KIT

- For live working operation at maximum voltage of 1 000 V AC - 1 500 V DC
- 1 Insulating blanket 1 m X 1 m Class 0 MP-220
- 4 Insulating clamps 80 mm for blanket MP-627-D
- 3 Insulating caps Ø 30 X 120 mm Class 0 MP-635/30 D
- 3 Insulating caps Ø 60 X 135 mm Class 0 MP-635/60 D"



CTUMP123 (0,36 X 0,66M)
CTUMP1231 (0,5 X 0,9M)
CTUMP1232 (0,8 X 1,2M)
INSULATING MAT

- Used to insulate bare or insufficiently insulated conductive parts for the duration of the work.
- Maximum operating voltage: 1,000 V AC - 1,500 V DC



CTUMP1111
INSULATING MAT

- Maximum operating voltage: 1000 V AC - 1500 V DC.
- Used to cover the floor for the electrical protection of operators in electrical installations.

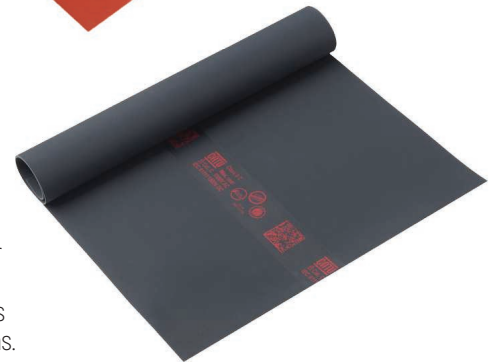

CTUMP220
1 M X 1 M INSULATING MAT

- Used as protection for workers operating on live parts or in the vicinity of live parts.
- For live line working.
- Operating voltage: 1 000 V AC - 1 500 V DC.
- In accordance with IEC 61112 class 0 standard and the specific properties:
 - Category C : Resistance to bending at very low temperature [-40°C].
 - Category H : Oil resistance.
- Operating temperature range : -40°C to +55°C.
- High puncture resistance.
- Dimensions: 1 x 1 [-0.01/+0.03] m

SAFETY WEAR

CTUAFG2300L
CTUAFG2300S
CTUAFG2300XXL
CTUAFG2300XXXXL

MULTI-RISK SWITCHING JACKET TO PROTECT AGAINST AN ELECTRIC ARC

- Adjustable hood for better protection of the head and the neck in case of higher risk, to be worn with a visor or a helmet.
- Front Velcro fastening along the entire length: easy to open and close.
- A back length of 121 cm to ensure sufficient protection of the operator down to the knees.



CTUM883374 (SMALL), CTUM883377 (MEDIUM), CTUM883378 (LARGE), CTUM883379 (XLARGE), CTUM883380 (2XLARGE), CTUM883381 (3XLARGE)

PARKA MULTI-RISK ARCFLASH SMALL

Multi-risk protection: protection against thermal hazards of an electric arc, heat and flames, rain protection, being anti-static, small splash of liquids chemicals. Central zip protected by flap and adjustable belt at the waist. 2 chest pockets and 2 hip pockets.



CTUMV991NSD

ORANGE COLORED ELASTOMER INSULATING APRON

- For low voltage use (class 0), up to 1 000 V AC / 1 500 V DC.
- Withstand voltage: 10 kV. Test voltage: 5 kV / 3 min.
- The material is also in compliance with special properties:
- Category A: acid-resistant.
- Category C: can be folded at very low temperature [-40°C].
- Category H: oil-resistant.

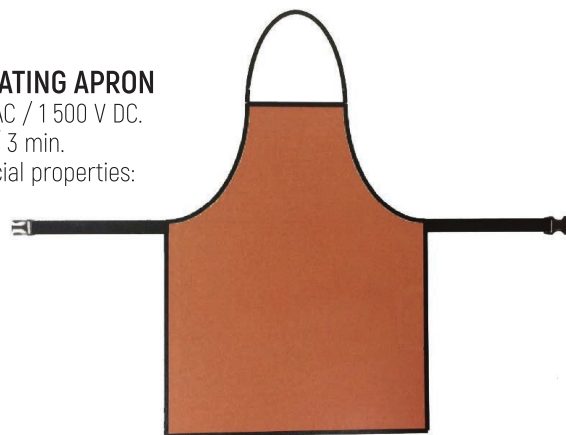

CTUMV22640 (SIZE 40), CTUMV22641 (SIZE 41), CTUMV22642 (SIZE 42), CTUMV22643 (SIZE 43), CTUMV22644 (SIZE 44), CTUMV22645 (SIZE 45) CTUMV22646 (SIZE 46), CTUMV22647 (SIZE 47)

SAFETY SHOES WITH INSULATING SOLE

- Indoor or dry environment use, low-cut leather upper, low and textile type, providing electrical hazard resistance up to 18 kV according to ASTM F2413:2018.
- Waterproof shoes for a wet atmosphere.
- Each insulating sole tested at 5 kV.
- Shoes with textile and breathable liner.
- Anti-penetration textile sole.
- Protection cap 240 J (20% above the standard).



CTUMV138M (SIZE M), CTUMV138L (SIZE L), CTUMV138XL (SIZE XL)
OVERBOOTS

- Class 1: 7 500 V AC, 11 250 V DC according to EN 50321-1:2018
- Meets the requirements of ASTM 1117 (20kV).
- Material : special compound formulation to ensure high voltage dielectric resistant.
- Slip resistance performance (SRC) compliant with SATRA TM144 standard.



SRWS31200

312 ARCFLASH SERIES FACE SHIELD

Sellstrom's Arc Flash face shields feature a unique molded polycarbonate window, impact and splash resistant. It provides clarity, without distortion, and panoramic vision. The specially formulated window features a light green tinted window that provides 55% light transmission and true color optics.



CTUM0286

FACE SHIELD

Protection against thermal effect of short-circuit electric arcs. To wear without helmet. Head adjustment by a ratchet. Anti-scratch and anti-fogging treatments. Screen height: 20,5 cm.





MAXICHARGER AC WALLBOX

- Compatible with all EV and Hybrid Plug-in Vehicles
- 25ft long Universal (J1772) Charging Cable and NEMA 14-50 Plug
- Contemporary Design, Dark Gray
- Wallbox with separate holster and cable management
- Autel Charge app enables remote start, stop, monitoring and scheduling
- Specially designed for Indoor or Outdoor use
- Wi-Fi / Bluetooth / Ethernet
- Three-year limited warranty

SMART CHARGING FROM YOUR SMARTPHONE

Charging your electric vehicle is now even easier than filling a gas. Now, with the MaxiCharge app, monitoring your charging process is quicker and more convenient than ever. At the tap of a finger, you can track, manage, and optimize your EV charging at any location, any time.



TAKE CHARGE OF CHARGING

With our one-stop SaaS solution, you can easily manage your charging network all in one place. Our charging management software lets you track and manage EV charging right from your smartphone or computer, allowing you full visibility and understanding.



Description	Power output	Power supply	Holster configuration	Touch Screen	Product Color	Mobile App	Cellular Modem
AULMC40AP14S MAXI US AC W10-N14 MAXICHARGER HOME 40 A AC Wallbox EV Charger With Separate Holster	Adjustable up to 40 amps	NEMA 14-50 PLUG	Separate	Indicator Lights	Dark grey		N/A
AULMC40AP6S MAXI US AC W10-N6 MAXICHARGER HOME 40 A AC Wallbox EV Charger With Separate Holster		NEMA 6-50 PLUG					
AULMC50AHS MAXI US AC W12 MAXICHARGER HOME 50 A AC Wallbox EV Charger With Separate Holster	Adjustable up to 50 amps	HARDWIRED	In-Body	Indicator Lights	Dark grey		N/A
AULMC40AP14I MAXI US AC W10-N14-H MAXICHARGER HOME 40 A AC Wallbox EV Charger With In-Body Holster	Adjustable up to 40 amps	NEMA 14-50 PLUG					
AULMC40AP6I MAXI US AC W10-N6-H MAXICHARGER HOME 40 A AC Wallbox EV Charger With In-Body Holster		NEMA 6-50 PLUG					
AULMC50AHI MAXI US AC W12-H MAXICHARGER HOME 50 A AC Wallbox EV Charger With In-Body Holster	Adjustable up to 50 amps	HARDWIRED	In-Body	Interactive 4G/LCD	Silver	N/A	
AULMCC50AHI MAXI US AC W12-L-4G MAXICHARGER COMMERCIAL C50 AC Wallbox EV Charger	Adjustable up to 50 amps & 45 Miles of range per hour	HARDWIRED					

SAFETY TOOLS

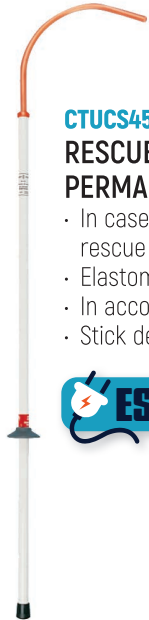

CTUCS452 RESCUE STICK WITH INSULATED PERMANENT HOOK 45 KV - 1,65 M

- In case of electric shock accident the rescue stick is used to clear away hazards.
- Elastomeric handguard.
- In accordance with the STC n°43 of CATU.
- Stick delivered with wall brackets CI-06-D.



CTUACA10 MAGNETIC SIGNAL CONE "ELECTRIC HAZARD" TO WORK ON EHV OR BATTERIES

- Positioned on the roof of an electric vehicle or on the metallic part, it allows an optimum 360° visualization of the electric danger.
- Installation and removal made easy thanks to the magnetic base (140 mm side) with strong adhesion in a triangular shape.



UVXRWS-50011 SAFETY CONE, 18" HEIGHT ORANGE

- Injection molded low density polyethylene with UV stabilizer will not discolor
- Non-porous surface resists dirt and grease resistant



ULIS-21635 HEAVY DUTY REFLECTIVE TRAFFIC CONES - 36", ORANGE

- Recommended for surveying or highway construction.
- Durable PVC. Use indoors or out.
- Weighted base offers superior stability. Stackable.
- Indented handle for easy transport.
- 3M reflective collars won't peel off.



CTUCZEVRESC RESCUE STICK WITH INSULATED PERMANENT HOOK 45 KV - 1,65 M

- Including the wall-support accessories:
 - 1 Rescue stick with insulated hook CS-45/2
 - 1 Wall box for insulated gloves CG-35-2
 - 1 Rubber insulating gloves with mechanical and Arc-Flash protection ATPV 12 cal/cm², APC 2, class 0 - 1 000 V AC - 1 500 V DC. Size 10 CGM-0-10
 - 1 Fire extinguisher for Li-ion battery CD-307



CTUKITVEH KIT FOR APPLICATION IN THE FIELD OF ELECTRIC AND HYBRID VEHICLES AND MACHINES FOR DELINEATION

- Suitable for electric and hybrid vehicles and machines.
- 6 Balasted boundary posts red and white AL-323.
- 1 Plastic chain with red and white links 25 m AL-31/25.
- 2 Plastic signs. Dimensions 450 x 150 mm. AP-72.



CTUAT5005 SAFETY ADHESIVE TAPE

- Enables temporarily delineation of an area.
- Self-adhesive PVC.
- UV resistant.



HAN66200 300' X 3" - CAUTION TAPE



ULIS-17842 ELECTRICAL TAPE - 2" X 20 YDS, BLACK

Electrical tape for splicing and insulating wires up to 600V. Rubber adhesive with soft polyvinyl chloride film backing. 11/4" core.





CTUKITVEHDEP
TOWING AND REPAIR KIT FOR EHV

Includes:

- 1 faceshield with headband to protect against short-circuit arcs MO-286. Complies with Arc Flash GS-ET-29: Class 1.
- 1 cover for protection and storage of the face shield M-87-384.
- 1 pair of short insulating gloves (28 cm), class 0 (1000 V AC / 1500 V DC), size 10 CG-0-10-R-28.
- 1 pair of cotton under-gloves CG-80-H.
- 1 Pair of short leather overgloves for the mechanical protection of insulating gloves, size 10 CG-984-10.
- 1 bag for protection and storage of gloves CG-36-1.
- 1 set of 40 "DAMAGED VEHICLE" removable stickers AT-81.
- 1 safety padlock with non-conducting shackle and retaining key PP-6-38-R-Z.
- 10 safety Tag-Out badges AP-460.
- 1 carrying bag MO-42/2.

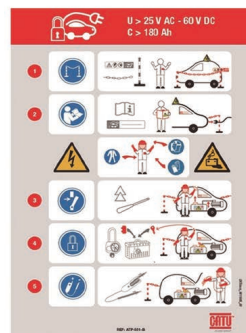

CTUKITVEHC
KIT FOR APPLICATION IN THE FIELD OF ELECTRIC AND HYBRID VEHICLES AND MACHINES FOR LOCK-OUT TAG-OUT OPERATIONS

Includes:

- 1 3-sided warning triangle ACA-10.
- 1 warning sign with suction cups. Dimensions 450 x 150 mm. AP-550-M2V.
- 1 adhesive plastic sign stating the Golden Rules. Dimensions A4. ATP-551/B.
- 1 safety padlock PP-6-38-R-Z.
- 10 safety Tag-Out badges. Dimensions 120 x 70 mm. AP-460.
- 1 LED voltage detector MS-917-PG.
- 1 Insulating wedge tool suitable for certain maintenance operations on electric vehicle batteries, especially for disconnection. MO-600.



CTUM07582D
MAGNET ON FLEXIBLE HANDLE

- In accordance with IEC 60900 standard.
- Operating voltage up to: 1 000 V AC - 1 500 V DC
- Entirely insulated.
- Magnet diameter : 6 mm
- Maximum load to the magnet: 0,750 kg.



CTUPP638RZ
INSULATING SAFETY PADLOCK WITH RETAINING KEY, NYLON SHACKLE 38 MM DIAMETER 6 MM

- For locking the separating devices (e.g. circuit breakers) to prevent their operation.
- Padlock with insulating shackle for use in low voltage 1 000 V AC - 1 500 V DC: tested and validated in accordance with the electrical test IEC 60900 (2012) §5.5.3.
- More secure locking: impossible to drop the key when the shackle is open, the key remains trapped.



CTUM0600
INSULATING WEDGE TOOL

- Suitable for lock-out procedure or maintenance operations on electric or hybrid vehicles.
- Especially allows to open the plastic covers protecting the ends of cables.
- Insulating tool for live working at low voltage.
- Maximum operating voltage: 1 000 V AC - 1 500 V DC.

DIAGNOSTIC TOOLS

DIAGNOSTIC TABLETS



AULMS909EV



AULMSULTRA EV

Hardware	AULMS909EV	AULMSULTRA EV
Connection	BLUETOOTH MAXIFLASH VCI	BLUETOOTH MAXIFLASH VCI
Screen	9.7INCH TOUCHSCREEN	12.9INCH TOUCHSCREEN
Processor	2.2GHz + 1.8GHz · OCTA-CORE	
Memory	128GB SSD / 4GB RAM	256GB SSD / 4GB RAM
Vehicle Coverage	US, ASIAN & EUROPEAN · ELECTRIC, GAS, DIESEL AND HYBRID VEHICLES	
OBDII Test Modes	ALL 10 TEST MODES · LIVE & FREEZE FRAME / ENHANCED MODE 6	
Service Resets	36 SERVICE FEATURES	
Diesel PM	RESET DIESEL EMISSIONS · LIGHT & MEDIUM DUTY VEHICLES	
System Diagnostics	ACCESS ALL MODULES	
Oscilloscope	—	VCI 5-IN-ONE DEVICE, VCI MULTIMETER, WAVEFORM GENERATOR, CAN BUS TESTER
Split Screen Display	VIEW MULTIPLE FUNCTIONS AT ONCE	



FLU1587FC **INSULATION** **MULTIMETER WITH FLUKE CONNECT**

A single tool that allows users to perform advanced insulation testing and true RMS digital multimeter functions in a compact handheld unit.

- CAT III 1000 V

TOPTDEVR5K **EV RESCUE 5K**

- The EV RESCUE 5k power station delivers reliable, instant power whenever and wherever you need it. Ideal for towing companies looking to charge electric vehicles dead on the side of the road or mobile technicians needing consistent voltage power supply, using clean, renewable power - no fumes, no noise and no excessive costs
- Simply flip the switch for silent, emissions-free portable power
- The EV RESCUE 5k can also be used to complement or completely replace gas/diesel generators



AULTESKIT **DIAGNOSTICS CABLE KIT FOR TESLA S AND X MODEL VEHICLES COMPATIBLE WITH MAXISYS TABLET**

Kit includes Cable LAN001: Connects to Tesla port X861 to activate Factory Mode; Connects to Tesla port X863 for diagnostics; Pre-2015 vehicles: port X863 is located on left side of instrument panel and for Post-2015 vehicles: port X863 is located below the central control screen; Cable CAN001: For diagnostics of post-2015 vehicles.; Cable CAN002: For diagnostics of pre-2015 vehicles.



AULEVDIAGKIT **EV DIAG UPGRADE KIT**

- The EV Diagnostics Upgrade Kit includes EVDiag Box, testing software, and adapters for specific vehicles to enable testing of electric vehicle battery packs. The EVDiag Box is compatible with the MaxiSys Ultra, MaxiSys Ultra ADAS, MaxiSys MS919, and MaxiSys MS909.
- Includes EVDiag Box, breakout leads and BMW, Tesla, VW adapters
- Includes EV battery pack diagnostic software upgrade



PPRPPDMM
CAT-IV 600V RUGGED DIGITAL MULTIMETER

- CAT-IV 600V Hybrid Safe AC/DC Voltmeter
- DC Voltage, AC Voltage TRMS, Ohm, Amp, Temperature meter
- Built Shop Tough with Heavy Duty Construction case
- Large 6000 Count LCD Display with Backlight for easy viewing
- Loud Indicator Tones for Shop Environments



BOSF00E9001013CM
540H CAT III MULTIMETER

- CAT III (1000v) safety rating for hybrid vehicle circuits
- Peak, Min/Max readings as fast as 1 millisecond
- Higher amperage test ranges, up to 20 Amps
- Inductive RPM clamp for conventional and DIS ignition systems
- Fused diagnostic test leads provide safe troubleshooting (up to 20 amps) at the circuit fuse location
- K-Type thermocouple for quick temperature measurement
- Large LCD display with bright backlighting and auto shutdown
- Tri-lingual user manual on CD (English, Spanish, French)
- Rugged nylon case with handle for efficient storage



FLU1507
INSULATION RESISTANCE TESTER

- Rugged, compact advanced insulation resistance tester for electrical contractors and industrial and commercial electricians
- Automatically calculates Polarization Index and Dielectric Absorption Ratio
- Makes repetitive tests simple and easy with a Compare (Pass/Fail) function



FLUFEV100
FLUKE FEV100 ELECTRIC VEHICLE CHARGING STATION EVSE TEST ADAPTER

- Check protective earth for correct wiring and functioning with the PE pre-test feature.
- Perform GFCI troubleshooting of EVSE and verify operation within safety standards.
- Test charging states of EVSE with CP state simulation.
- Verify charging voltage and maximum available current using a multimeter.
- SAE J1772 compliant to North American standards.

PPRPPVT750LCDCBINT
POWERPROBE TWO-POLE VT (VOLTAGE TESTER)

The VT750LCD is a compact reliable robust automatic voltage tester up to 750V. The testers can measure and indicate the exact voltage (AC/DC), phase indication, phase rotation and continuity, RCD, and resistance via an LCD.

- 2,000 count digital display
- AC / DC 750V capability
- Dual display for ACV measuring with Frequency
- 2K Ohms Resistance range
- 1K Hz Frequency Counter
- Integrated single pole test for phase detection
- IP65 for outdoor use



CTUMS917L
LOW VOLTAGE DETECTOR DETEX

- Check the presence of voltage.
- Checks voltage levels from 12 to 690 V AC, 750 V DC.
- Sound and light continuity for a non-live circuit (threshold of 200 Ω).
- Search for the polarities of a DC circuit.
- Unipolar phase identification.
- For indoor/outdoor use.
- Fitted with test lead points Ø 2 mm L: 19 mm.
- Total safety with hazardous voltage indicator light (> 50 V).
- Protection level: IP65/IK06.
- Self test button to discern the verification of the good functioning and the continuity function.
- Completely modular and adjustable to eclipse sockets.
- LED display.
- Optional accessories: Carrying bag with belt loop, Ref. M-87285 & Holder, Ref. M-952325.



KLEET600
INSULATION RESISTANCE TESTER

- The voltage tester tests the insulation resistance up to 4000MΩ at 125V, 250V, 500V and 1000V DC.
- Megohmmeter with test and lockout buttons for simple insulation testing.
- Warning alarm and high voltage icon for voltage detection.
- Measures up to 1000V AC/DC, resistance and continuity.

THE ONE LIFT TO SERVE THEM ALL!



SPOA10N20MORD ELEVATING THE FUTURE OF LIFT TECHNOLOGY

Also available in blue: SPOA10N20MOBL

- 3 3/8" minimum adapter height
- 20% more reach than 3-stage arms with thread-up adapters
- 30% larger arm sweep than conventional 2-stage arms with flip-up adapters
- Comes standard with adjustable round, truck and stackable adapter extensions
- Available with SHOCKWAVE™
- ALI Gold Certified

\$ PRICE ON DEMAND

30% LARGER ARM SWEEP

20% MORE REACH

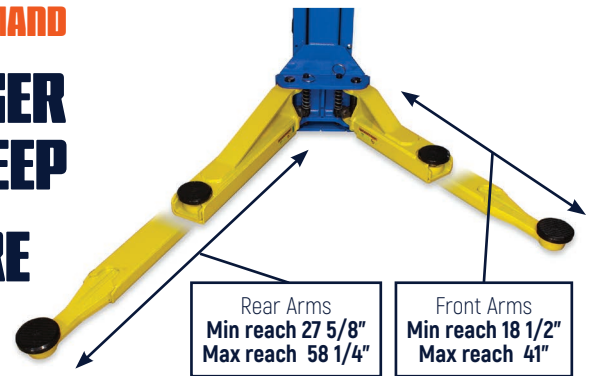

SLW210 WIDE 10,000 LBS. CAPACITY

SLW212 WIDE 12,000 LBS. CAPACITY

The wide, unobstructed design allows better access under the cab and reduces the risk of contact between the elevator and vehicle parts.

By 2030, 1 in 3 cars sold will be battery electric. Rotary's SMARTLIFT WIDE floor elevator design is perfect for servicing all types of vehicles - including electric cars and trucks.

- Includes two-piece, three-stage TRIOTM arms with truck adapters.
- Designed for light and medium duty trucks.
- Available with SHOCKWAVE™ DC battery power.
- Multi-position wheel locator plate
- Available with round rubber adapters RA
- Comes standard with lightweight, adjustable truck adapters with rubber pads.
- One set of stackable adapters is standard.

\$ PRICE ON DEMAND

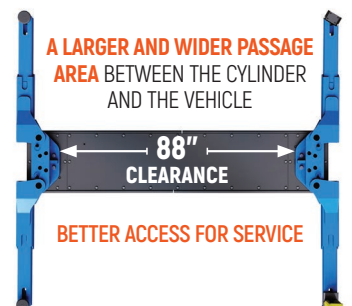



ATEATTD-EVBL3310 ATLAS® ELECTRIC BATTERY LIFTING TABLE

The ATLAS® Electric Battery Lift table combines a robust lifting capacity, versatile platform adjustments, and thoughtful design features, making it an adaptable solution for lifting electric battery packs on hybrid & electric vehicles. The ATLAS® Electric Battery Lift can also be used to lift engines & transmissions.

- 3300 lbs Capacity
- Requires 110v Power Supply
- CSA/cETL Certified Power Pack
- Maximum Lift Height: 71 1/4 inches
- Minimum Lift Height 29 1/4 inches
- Expandable Lifting platform length: 68 1/4 - 79 3/4 inches
- Platform width: 31 3/4 inches
- Tilting angles of +/- 5.1° (left/right) and +/- 2.2° (front/rear)
- Wired remote control for lifting & tilting
- 2 Year Limited Warranty

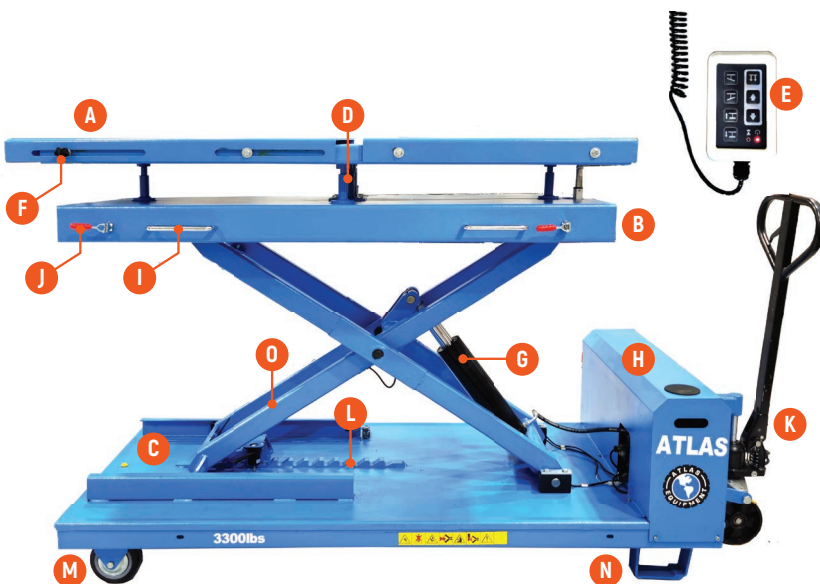

- A** Tabletop with multiple threaded locations for accessory attachments
- B** Lower table provides support for the upper table.
- C** Base frame
- D** Linear actuator enables automatic tilting of the top table in both left/right and front/rear directions.
- E** Wired control pad controls: power on/off, multi-directional tilting, lift up/down functions
- F** Extension of the top table can be achieved by releasing the locking screw
- G** Lowering & lifting of the bottom table done by operating the remote control, driven by the hydraulic cylinder
- H** Control module unit housing
- I** Handles for manual lateral movement; when all locks are release
- J** Manual lock release for lateral movements
- K** The mobile jack is affixed in front of the base frame to enable the movement of the lift; like a pallet jack
- L** Built in safety lock ladder incorporated for added safety
- M** Front caster wheels for easy portability.
- N** Enforced legs allow for stability when in use.
- O** The bottom table is connected to the base frame through a scissor lifting mechanism.

THIS BRAND NEW PRODUCT WILL BE IN STOCK SUMMER 2024

OTC1595A
2,500 LB. AIR/HYDRAULIC
POWERTRAIN LIFT

- 2,500-lb. pneumatic/hydraulic lifting system.
- Scissor design allows access to all four sides of a component.
- Powered by a pneumatic or hydraulic foot pump for precise control of lifting and lowering.
- Independent adjustment screws allow the table to be tilted 15° from side to side, or front to back, and ensure maximum table stability in any position.
- Meets ASME PASE standards



INT3182
2,500 LB.
POWERTRAIN LIFT TABLE

- Mechanical safety latches at 30%, 50% and 80% of max height provides additional operator safety
- Air/hydraulic foot pump with nine foot extension allows access anywhere around the work area perimeter and provides hands free operation
- Scissors lift design allows access to all four sides of a component
- 8" diameter swivel casters for easy maneuverability under the heaviest loads
- Lifts from 33" to over 77"



ROTLT33A000YEBK
HYDRAULIC LIFTING TABLE,
CAPACITY 3,300 LBS

The LT33A single section scissor lift design has a wide, stable base to help technicians securely and efficiently remove, and install heavy vehicle components from electric battery packs, engines, and transmissions.

- Split sliding top
- Rear platform tilt adjustment
- Side to side platform alignment
- Air released mechanical locks
- Air system controls
- Foot pedal controls raise and lower lift
- Fixturing holes on lift top surface
- Multi-directional casters



TIT21130
4 PC. TESLA JACK PAD SET

These pads are essential on models S, 3, X, or Y to protect the battery, the lower car body, and the vehicle paint



INT380
AFF - RUBBER JACK
PAD LIFTING ADAPTER

Tesla Models 3,S,X - For Use with Service Jacks & 4 Post Lifts



INSULATED SOCKETS



INSULATED SOCKET SET

- Locking Endcap Torque Adjuster For Easy Adjustment
- Accuracy +/- 10% Accuracy
- Dual Scale Reading Ft./lbs. - Nm
- Fully Visible Reading Scale For Easy Reading No Hassel Adjustment
- Separate Socket Release Button



WIH30192

16 PIECE INSULATED 3/8" DRIVE TORQUE SOCKET SET - METRIC

Set Includes: 8, 9, 10, 11, 12, 13, 14, 15, 16, 17, 18, 19, 20, 125mm

KNP989911S4

10 PIECE 3/8" DRIVE INSULATED SOCKET SET - METRIC

Includes 10 insulated tools for working on electrical installations 3/8" drive Metric in a shock resistant plastic case. The case has a foam recess for tools for easy storage and identification.



ESHOK-GUARD™

Protect yourself from electric shock with Crescent's new patented isolated technology, eSHOK-GUARD, providing insulation of up to 1,000 volts.

- Isolation zone insulates standard bits with protection up to 1000V
- Withstands heavy use in impact applications
- Magnetic tip keeps fasteners securely in place



CRSCAEAD316

ESHOK-GUARD™ SOCKET ISOLATOR 1/4" X 2"



CRSCAEAD324

ESHOK-GUARD™ SOCKET ISOLATOR 3/8" X 2-1/4"



CRSCAEAD332

ESHOK-GUARD™ SOCKET ISOLATOR 1/2" X 2-1/2"



CRSCAEBH2C

ESHOK-GUARD™ MAGNETIC ISOLATED BIT HOLDER 1/4" X 3"



TIT66100

18 PIECES INSULATED SOCKETS 1/4" SOCKET

- Includes: 4, 4.5, 5, 5.5, 6, 7, 8, 9, 10, 11, 12, 13 and 14mm
- Extensions: 2, 3, 4 and 6 inches
- Fully insulated, quick-release reversible ratchet 1/4"
- Manufactured in Taiwan to DIN standard and certified to EN 60900



WIH31391

13 PIECE INSULATED SOCKET SET 1/4 IN. DRIVE - METRIC

- Insulated 1000 Volt Rated 10,000 Volt Tested
 - High Visibility Coatings On Sockets
 - Professional Series Long Life Insulated
 - Insulated 1/4" Drive Metric Socket Set, 13 Piece.
- Includes: 5.0, 6.0, 7.0, 8.0, 9.0, 10.0, 11.0, 12.0, 13.0, 14.0mm Sockets, 50mm & 100mm Extension Bar & 1/4" Drive Ratchet. Chrome-vanadium steel, forged, oil-hardened sockets. 1000Volt rated. In Storage Box.



AIR CONDITIONING



TRATP100EV-5

5 OZ (148 ML) FOIL POUCH WITH POE-BASED A/C OIL FOR ELECTRIC VEHICLES

(compatible with R-1234yf and R-134a systems)



TRATP100EVD-5

5 OZ (148 ML) FOIL POUCH POE-BASED A/C OIL WITH FLUORESCENT DYE FOR ELECTRIC VEHICLES

(compatible with R-1234yf and R-134a systems)

5 OZ (148 ML) FOIL POUCH

"EV A/C Oil compatible with R-134a & R-1234yf systems sealed in a moisture-resistant foil pouch. Protects against contamination. Perfect for preventative maintenance. Specially formulated with high-dielectric properties to protect all hybrid/EV system components - including electrically driven compressors."



UVU488046PBD

PAG 46 OIL WITH A/C EXTENDYE™ BOTTLE (8 OZ/240ML)

- A/C ExtenDye™ is a super-concentrated UV dye that includes an enhanced additive package to reduce wear, extend component life, and improve the efficiency of the A/C system.
- Hybrid Safe: Specially formulated to protect all hybrid AC system components (including electrically driven compressors).



UVU480501

LEAKGUARD ONSHOT A/C SUPPLEMENT WITH EXTENDYE CARTRIDGE

- Specially formulated to protect all hybrid AC system components (including electrically driven compressors)
- Quickly and effectively stops leaks with Leak + Guard technology
- Detects leaks with premium UV dye
- Additive package enhances A/C system performance and prolongs life
- Will not harm A/C system or recovery equipment
- Works with metal Spotgun Jr. injection system



UVU499024A

A/C EXTENDYE BOTTLE (10Z / 30ML)

- A/C ExtenDye Bottle (1 oz. / 30mL)
- Standard Pack of six (6) Bottles
- Service Stickers
- Hybrid safe*

*Specially formulated to protect all hybrid AC system components (including electrically driven compressors)



UVU490100

SPOTGUN® INJECTION STARTER KIT

- This kit includes everything you need for automotive service:
- SpotGun® Injector with Purge Valve Adapters
- R-134a and R-1234yf Couplers
- (2) SpotGun® Service Hose Assemblies
- (1) Universal Oil Cartridge (8 oz/240 ml)
- (1) ExtenDye™ Cartridge (8 oz/240 mL)
- Service Maintenance Stickers



TRATP9814EV-BX
MINI-EZ™ POE-BASED EV
A/C DYE INJECTION KIT

Mini-EZ POE-Based EV A/C dye injection kit with TP9815EV-P3 dye cartridges (compatible with R-134a and R-1234yf EV systems), solid-brass swivel-type R-134a coupler with check valve and purge fitting, R-1234yf adapter



TRATP9815EV-P3

(3) 0.25 OZ (7 ML) MINI-EZ™ SINGLE-DOSE
POE-BASED EV A/C DYE CARTRIDGES

Three 0.25 oz Mini-EZ single-dose POE-Based EV A/C dye cartridges. Compatible with R-134a and R-1234yf systems. Mini-EZ EV A/C dye cartridges for single-billable dosing. Specially formulated with high-dielectric properties to protect all hybrid/EV system components - including electrically driven compressors.



TRATPOPUV20EV

MINI-EZ™ POE-BASED EV
A/C LEAK DETECTION KIT

Mini-EZ POE-Based EV A/C Leak Detection Kit includes (3) 0.25 oz (7 ml) single-dose EV A/C dye cartridges, TPOPUV OPTI-PRO UV flashlight, R-134a coupler, R-1234yf adapter, GLO-AWAY Plus, glasses, and medium blue carrying case (CE, UKCA)



ROBAC1234-9
CONNECTED R1234YF AC MACHINE

- New 10" capacitive LCD touch screen and intuitive user interface makes navigation much easier and beginning service quicker
- Incorporated Wi-Fi and Bluetooth wireless technology enable many new features and capabilities making this the most advanced A/C RRR machine on the market today
- Automatic updates ensure your machine always has the most current software, as well as access to new features and capabilities as they become available



MSCCOMMANDER4000
SAE J2843 CERTIFIED AUTOMATIC
R1234YF AND HYBRID RRR MACHINE
WITH IDENTIFIER (110 V)

- Touch screen color command center
- Thermal printer
- Hybrid and standard 1234YF vehicles
- Hose and vehicle A/C system flush
- Commander 4000 SAE approved 1234YF RRR machine with color touch screen command center.



ROB34788NI-H
PREMIER R-134A REFRIGERANT
RECOVERY, RECYCLING, AND
RECHARGING MACHINE, RRR AC
MACHINE, FOR HYBRID AND
NON-HYBRID VEHICLES

- Safely service both conventional and high voltage A/C systems
- 98.5% Recovery
- Fully automatic operation
- Automatic internal tank fill

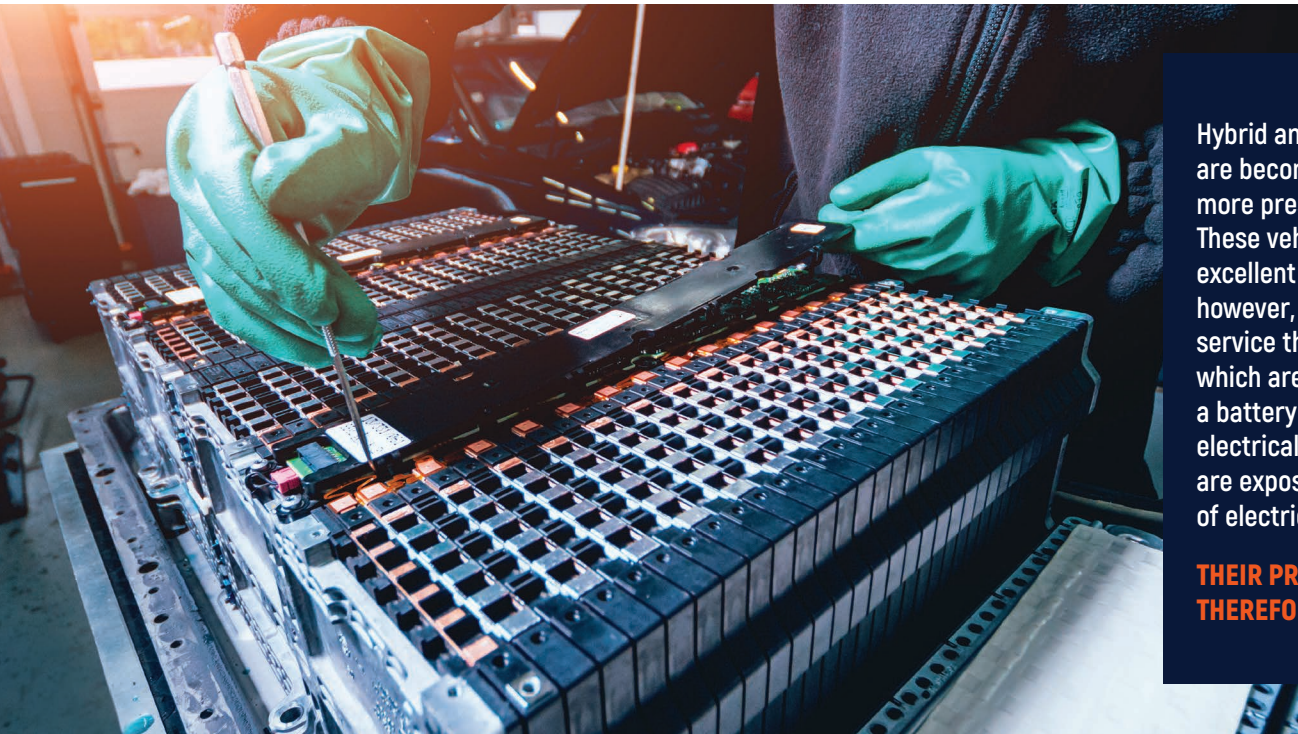

Hybrid and electric vehicles are becoming more and more present on our roads. These vehicles offer excellent fuel efficiency, however, technicians who service these vehicles which are equipped with a battery and high-voltage electrical components, are exposed to the risk of electrical discharges.

THEIR PROTECTION IS THEREFORE ESSENTIAL.

3 WAREHOUSES IN CANADA TO SERVE YOU BETTER



**QUEBEC
(HEAD OFFICE)**
88 Ch. Du Tremblay
Boucherville, QC J4B 6Z6
514-327-0222



CALGARY
10707 25 St NE, Unit 110
Calgary, AB T3N 0A1
866-284-8604



ONTARIO
448 N Rivermede Rd,
Vaughan, ON L4K 3M9
877-669-8512



SOMETHING IS MISSING? All you need to service EV on www.toolweb.ca. Research on "insulated" for more than 1,000 products.



www.toolweb.ca | info@isncanada.ca | 1-888-327-0222